

OA Support to PRT Meymaneh

Steinar Gulichsen, Elin Marthinussen and Bård Eggereide

Norwegian Defence Research Establishment (FFI)

20 January 2011

FFI-rapport 2010/02151

1122

P: ISBN 978-82-464-1864-3

E: ISBN 978-82-464-1865-0

Keywords

OA støtte

PRT

Afghanistan

Operasjonsanalyse

Approved by

Frode Rutledal

Project Manager

Espen Skjelland

Director

English summary

FFI has since December 2008 deployed operational analysts to the PRT Meymaneh. This report documents experiences and lessons identified from the first three deployments. The concept for OA support is also described, in addition to a short description of the PRT's history and organization.

Sammendrag

FFI har siden desember 2008 deployert operasjonsanalytikere til PRT Meymaneh. Denne rapporten oppsummerer erfaringer og lærdommer fra de tre første deployeringene. Konseptet for OA-støtte blir også beskrevet, i tillegg til en kort oversikt over PRT-ets historie og organisasjon.

Contents

1	Introduction	7
1.1	Previous experiences with OA support to operations	7
1.2	The ANTILOPE project	8
2	PRT Meymaneh	8
2.1	History	9
2.2	Organizational structure	10
3	The Norwegian OA concept	11
3.1	Military contract	12
3.2	Reach back	12
3.3	Preparations	13
3.3.1	Norwegian Defence Command and Staff Collage	13
3.3.2	OA courses in Birmingham and Australia	14
3.3.3	Unit pre-deployment training	14
3.4	Experiences with the OA concept	14
4	OA support to PRT Meymaneh	15
4.1	OA support to PRT XII	15
4.2	OA support to PRT XIII	17
4.3	OA support to PRT XIV	18
4.4	Common OA tasks	20
5	Lessons identified	21
	Appendix A PRT MEY Info sharing database	23
	Abbreviations	25
	References	26

1 Introduction

Norway has, since December 2008, deployed operational analysts with the Norwegian led Provincial Reconstruction Team (PRT) Meymaneh in Afghanistan.¹ Prior to this, operational analysis (OA) has not been practiced on a regular basis in support of the Norwegian operational forces. This report describes the concept and main tasks of the OA support to PRT Meymaneh as well as the lessons identified as part of this contribution.

The background for establishing the OA concept and previous experiences of Norwegian OA support is described in the following sections. The Norwegian led PRT Meymaneh² is then described in Chapter two, both its history and its organizational structure as of today. Chapter three and four describe the OA concept, in the preparation and in the field phase, whereas the last chapter describes the lessons identified.

1.1 Previous experiences with OA support to operations

Until December 2008, operational analysis (OA) had not been practised on a regular basis in direct support of international military operations. However, Norway has contributed with sporadic analytical support to international military operations. To be able to contribute with continuous support, a project was established at the Norwegian Defence Research Establishment (FFI) in order to build competence within this field.

FFI has also supported the Norwegian Joint HQ (NJHQ) with analytical support (2003–2008). This support was, however, limited to one analyst. The main emphasis for the analyst at the NJHQ was concept development and experimentation (CD&E) [1].

1997: Stabilisation Force in Bosnia and Herzegovina (SFOR)

The assessment cell in SFOR included two civilian analysts and five officers. The positions were originally manned by NATO Consultation, Command and Control Agency (NC3A), but from June till November 1997 FFI manned one of the positions. The period was divided between three analysts, deploying about 6 weeks each. The 6 week rotation was found to be too short in order to get a situational understanding and provide good analyses.

Some of the assignments of the assessment cell were:

- Initiate measuring of effectiveness
- Maintain the non-military database
- Internal assessments
- Lessons learned process

¹ The position is adopted and filled by the Norwegian Defence Research Establishment (FFI).

² No exact spelling of the city name Meymaneh exists today. In this report we have used the spelling used by the PRT throughout the contingents covered in the report.

2001: Kosovo Force (KFOR)

The OA cell in KFOR, contingent five, consisted of four civilian analysts, three from Norway and one from Denmark, and one military analyst from US Army Europe.

The main tasks of the OA cell were:

- Campaign assessment
- Development of courses of action
- Support the development of a strategy to improve the security and reduce tensions in the area

2008: Nordic Battle Group (NBG)

NBG was on readiness from January till July 2008. The OA cell consisted of two civilian analysts, one from Sweden and one from Norway.

The main tasks of the OA cell were:

- Risk assessments
- Lessons identified and learned
- War gaming and structuring multiple criteria solutions

1.2 The ANTILOPE project

In order to provide continuous analytical support to military operations, the project Analysis Support to Military Operations (ANTILOPE), was established at FFI in 2007. The aim was to build up a pool of deployable operational analysts in order to provide decision support during planning and execution of military operations. It was agreed that support to the Norwegian led PRT Meymaneh should be the main effort for the project. The first operational analyst deployed with PRT Meymaneh, Contingent XII, in December 2008. One of the main tasks for the analyst is to conduct campaign assessment and analyse progress in the Faryab province. This is discussed further in Chapter four.

2 PRT Meymaneh

As part of the International Security Assistance Force's (ISAF) effort in Afghanistan, joint military-civilian Provincial Reconstruction Teams (PRTs) are set up at provincial level. Their goal is to pave the way for a gradual transition from an environment where international military forces are necessary to an environment in which Afghan national and sub-national government institutions are soundly established and functioning, with PRTs in turn becoming unnecessary [2].

Norway is in lead of one of the 27 PRTs in Afghanistan.³ The PRT is located in the Faryab province in north-western Afghanistan, with the HQ in the provincial capital of Meymaneh. Its mission statement is as follows:

*As directed by Regional Command North and co-ordinated with national authorities, PRT Meymaneh will assist Government of Afghanistan in Faryab province in building security, governance and promote development in order to establish a safe and well governed Afghanistan.*⁴

Although the statement includes both military and civilian objectives there is a strong emphasis on making clear and distinct boundaries between the civilian and military contributions. In general, the security is handled by the military component, development and reconstruction is the responsibility of the civilian component, while both components share the responsibility of contributing to building the Afghan official structures.

2.1 History

Since NATO resumed command of ISAF in 2003, the Alliance has gradually expanded the reach of its mission, originally limited to Kabul, to cover all of Afghanistan's territory.⁵ 1st of July 2004 ISAF formally took over responsibility for the stabilisation force in Meymaneh from the American led Operation Enduring Freedom. The official name of the stabilisation force is Provincial Reconstruction Team (PRT) Meymaneh. In the beginning, PRT Meymaneh was under British command with forces from the UK, Norway and Finland and in addition it was 27 locally hired workers (guards, interpreters, etc.). The PRT had only three civilian advisors in the beginning (a political advisor (POLAD), a police and justice advisor (LEGAD) and a development advisor (DEVAD) – all of them Finnish).⁶ The PRT was located in the city centre of Meymaneh.

During the first years PRT Meymaneh consisted of about 75 soldiers from UK, Norway and Finland⁷. In September 2005, Norway resumed command of PRT Meymaneh and UK withdrew their troops. Norway reinforced the PRT with additional 30 troops and Iceland contributed with a military observation team (MOT) consisting of 8 soldiers. The PRT then consisted of troops from Norway (50, civilian and military), Finland (30, civilian and military) and Iceland (8). In addition it was about 30 locally hired workers.⁸

On the 7th of February 2006 the PRT Meymaneh camp was attacked by about 300 armed persons.⁹ It was a serious incident and late April 2006 it was decided, because of the security situation and

³ As of November 2010.

⁴ Royal Norwegian Embassy in Kabul, http://www.norway.org.af/News_and_events/prt/faryab1/

⁵ NATO's role in Afghanistan, http://www.nato.int/cps/en/natolive/topics_8189.htm

⁶ Meymaneh, kapittel 1, <http://www.mil.no/start/article.jhtml?articleID=184483>

⁷ Meymaneh, kapittel 2, <http://www.mil.no/start/article.jhtml?articleID=187305> and Meymaneh, kapittel 3, <http://www.mil.no/start/article.jhtml?articleID=184481>

⁸ Meymaneh, kapittel 5, <http://www.mil.no/start/article.jhtml?articleID=186028>

⁹ Meymaneh, kapittel 6, <http://www.mil.no/start/article.jhtml?articleID=186031>

the need for more space due to additional troops, to move the camp from the city centre to the outskirts of the city. The PRT moved into the new camp in June 2007.¹⁰

During the fall 2006 the amount of people in the PRT increased from about 100 to 150. Norway increased its contribution from 70 to 100, Finland maintained a force of 30 soldiers, and in addition 25 Latvian soldiers arrived.¹¹ The size of the PRT continued to increase in 2007 to about 165 soldiers¹² from Norway, Finland and Latvia during the first half of 2007, and to about 200 soldiers¹³ during the fall 2007.

The PRT continued to increase in 2008. In the beginning of 2008, it was about 250 persons, about 150 of these from Norway.¹⁴ During this period the PRT was reinforced with a new medical capacity, when the Norwegian Aeromedical Detachment (NAD) arrived, adding 50-60 soldiers from the Norwegian Air Force to the PRT. In June, the PRT increased noticeably to about 400 persons. This contingent included about 110 soldiers from Latvia and one from Iceland (as part of the Norwegian contribution).¹⁵

In 2009 and 2010, the PRT has been steady at about 400 personnel, with about 120 Latvians, 6 Macedonians and 1 Icelander (as part of the Norwegian contribution).¹⁶

2.2 Organizational structure

The many nations commanding the different PRTs has resulted in a variety of organizations in terms of the functions and resources available. Hence each PRT has its own recognisable national features [3]. This is also in line with the PRT Handbook, stating that “Factors within the Provinces such as: the security situation, the status of reconstruction, development, effectiveness of governance institutions, the presence of other International organizations (IO) and agencies will all play a role in defining the specific manpower and functional expertise required of each PRT” [4].

The military elements of the PRTs are national contributions to ISAF and fall under COMISAF’s command. The civilian elements of the PRTs are generally drawn from national government ministries and IOs and remain under national direction. A PRT’s military-civilian composition defines its capabilities.¹⁷

¹⁰ Ny sjef i Meymaneh, <http://www.mil.no/fof/start/article.jhtml?articleID=141999>

¹¹ Meymaneh, kapittel 7, <http://www.mil.no/start/article.jhtml?articleID=186041>

¹² Meymaneh, kapittel 8, <http://www.mil.no/start/article.jhtml?articleID=184372>

¹³ Meymaneh, kapittel 9, <http://www.mil.no/start/article.jhtml?articleID=184388>

¹⁴ Meymaneh, kapittel 10, <http://www.mil.no/start/article.jhtml?articleID=184409>

¹⁵ Meymaneh, kapittel 11, <http://www.mil.no/start/article.jhtml?articleID=184456>

¹⁶ Meymaneh, kapittel 12, <http://www.mil.no/start/article.jhtml?articleID=185102>

¹⁷ De Coning et al describes the PRT concept as “an applied tactical-level whole-of-government approach. Each PRT is encouraged to include, in addition to its security (military) element, political advisors, development advisors, police and or rule-of-law advisors, as well as any others (like governance, gender, counter-narcotics advisors, etc.), as appropriate, depending on the local context of each PRT. The PRT concept thus provides for the combined deployment of experts in several fields and from a range of government agencies, with the expectation that their co-location will result in improved whole-of-

From the description of how PRT Meymaneh has developed during the time of Norwegian lead responsibility it is also evident that the organizational structure of the PRT has changed a lot. Figure 2.1 gives the structure as of May 2010.

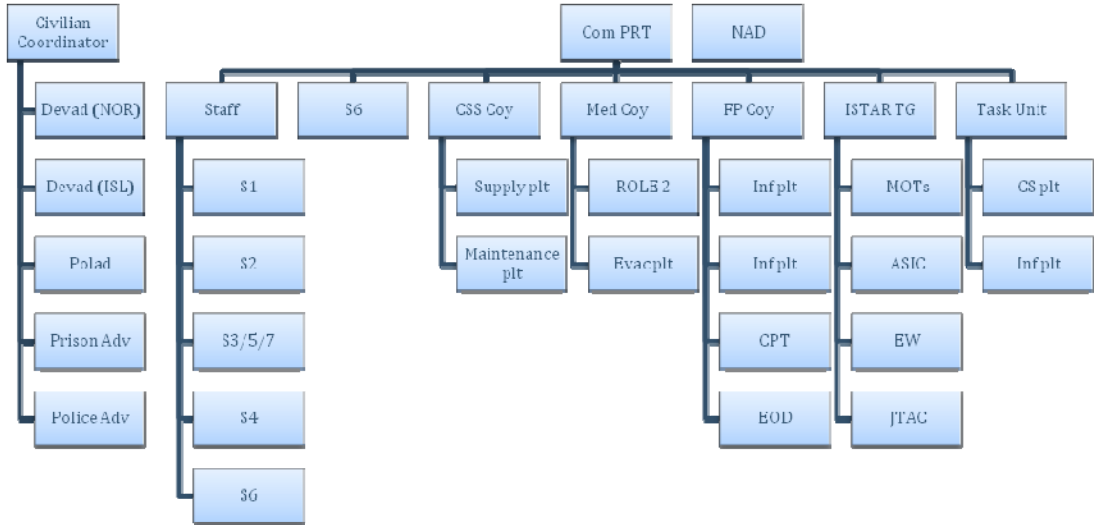

Figure 2.1 PRT Meymaneh organization as of May 2010

As depicted in the figure, the commander of the PRT only has command over the military side of the PRT whereas the civilian coordinator has command of the civilian capabilities of the PRT with the exception of the police advisors whom have their own chain of command. This requires extensive coordination within the organization in order to achieve an effect based or whole-of-government approach.

3 The Norwegian OA concept

The ANTILOPE project is the first systematic approach to operational analysis in support of Norwegian operational forces. Until the start of the project, the approach has been more on an ad hoc basis, see Chapter one. Within the reorganized Joint Operational Headquarter, the military organization has also adopted a more systematic approach to OA with a Section for analysis and concept development.¹⁸ However, currently there is no plan or capacity to deploy OA personnel from this section to Afghanistan.

This chapter gives a short description of how the current Norwegian OA concept is put into practice with emphasis on the administrative issues concerning the deployment of a FFI scientist.

government coordination. The end-result is expected to have a more system-wide or multi-dimensional impact on the stabilization and reconstruction goals and objectives of the international intervention, within each PRT's area of operation" [5].

¹⁸ The section is organized as part of the J5 branch.

The next chapter documents the actual support to PRT Meymaneh and also gives some examples of different types of tasks the deployed analysts have conducted.

3.1 Military contract

The scientist from FFI selected to deploy as an operational analyst is, under the current regime, given a leave of absence from FFI during the preparation and deployment period. During this period the analyst signs a standard contract for deployment to international operations with the Norwegian Armed Forces. This is the same contract as all personnel that are recruited for international operations signs.

As a consequence of signing a contract with the Armed Forces, the analyst is regarded as an officer for the duration of the contract period. Currently the analyst is given the rank of major, to reflect the level of education needed. The Armed Forces are at present in the process of implementing a system of civilian ranks for civilian personnel deploying to international operations. The system is based on the NATO system, with a direct link between the civilian and military ranks. Under this system the analyst would be given the rank of C-3 which is comparable to the military rank OF-3 or major.

Another aspect of signing a contract and thereby being regarded as an officer is that the analyst is armed as any other soldier when deployed. The situation rarely requires the analyst to leave the camp in Meymaneh city, but if needed it is imperative that she/he is able to take responsibility for her/his own security in the same way as any other soldier in the unit. The necessary training in the use of the assigned fire arms is given during the preparation period.

3.2 Reach back

Reach back can be a useful tool for the deployed analyst, and especially when only one analyst is deployed at a time. Being only one analyst, the tasks presented to the analyst can at times exceed her/his capacity. It is then useful to be able to utilize the reach back capacity at FFI to relieve some of the work load. The analysts deploying come from a wide variety of backgrounds and therefore the tasks can also go beyond their area of expertise. Hence, the reach back capacity may once again be useful.

To support the deployed operational analyst, FFI therefore provides reach back. This is carried out through a reach back team sited at FFI via weekly phone conferences and e-mail. In this manner, the analyst has access to all the fields of research at the institute, e.g. technology, anthropology and security policy. Figure 3.1 illustrates the concept of reach back at FFI.

One of the biggest challenges when it comes to reach back is the ability of the home organization to maintain an acceptable level of situational awareness. Since FFI is not part of the chain of command, very little information will automatically accrue to the Institute. To remedy this situation, the reach back concept utilizes the previously deployed analysts actively in the reach

back role, with the latest deployed analyst acting as the point of contact (POC) when she/he returns to FFI.

The POC has, as depicted in the figure, the ability to utilize the entire width of competence at the institute in solving a specific reach back task, by assigning the task to the appropriate research project at the Institute.

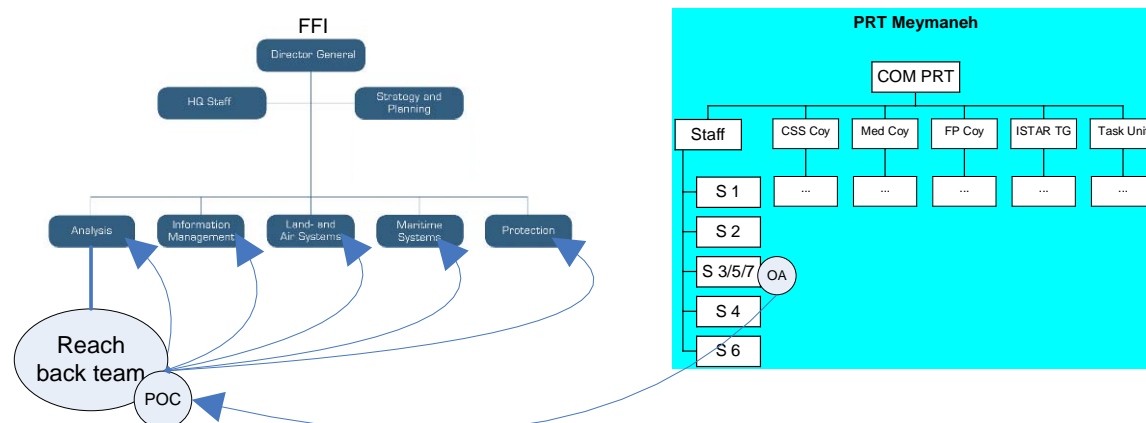

Figure 3.1 Reach back concept at FFI

3.3 Preparations

The preparations for deployment will undoubtedly vary based on the experiences and background of the analyst deploying. The formal courses presented in this paragraph describe some of the possibilities available. In addition, the analyst is usually integrated in the work of the ANTILOPE project, including the POC support team (see Chapter 3.2), as far as possible.

3.3.1 Norwegian Defence Command and Staff Collage

When deploying to a mission as part of a military unit it is important to have a good understanding of how this unit operates, which staff procedures that exist and how these all work together. This is essential in order to secure that the analyst is able to understand where she/he might contribute, but also in order to make sure that the analyst doesn't hamper the work of the staff.

Since most of the deployed analysts have little knowledge in this area prior to deployment, FFI have an agreement with the Norwegian Defence Command and Staff College (NDCSC) allowing 1–2 analysts to attend the Joint Operations course prior to deployment. The Joint Operations course is part of the Master of Military Science degree and aims to provide the students with knowledge on the military planning process and how a military headquarter functions on the operational level. Even though a PRT, as the operational analyst is an integral part of, is not operating on this level, the basic knowledge acquired during the course has proven to be very useful to the analyst. A description of the course and experiences from participation can be found in [6], [7], [8] and [9].

3.3.2 OA courses in Birmingham and Australia

To get an introduction to operational analysis, some of the analysts have been participating on basic OA courses. One of the courses is set up by the Operational Research Society in England and is a civilian OA course. This gives the analyst a broad introduction to OA. Another course is set up by the Australian Armed forces and DSTO¹⁹. This is a course customised to analysts who will deploy with military units. A description of the courses can be found in [10] and [11].

3.3.3 Unit pre-deployment training

As described in Section 3.1, the analyst signs a standard deployment contract with the Norwegian Armed Forces when deploying as an operational analyst. As a part of this contract, the analyst follows the unit's basic pre-deployment training over a course of 3 months. This training is designed to make the soldiers ready for deployment and covers training in a wide range of different areas. Some of the areas covered in the training are:

- International law and the law of armed conflict
- Cultural understanding
- Basic medical training
- Basic weapon skills

In addition to these general topics, all sub-units are given ample time to train on individual skills necessary for the different units. In the case of the operational analyst, with the staff as his primary sub-unit, time to train the different elements of the staff in a planning situation is given, as well as time to establish a basic situational awareness of the area of operations.

3.4 Experiences with the OA concept

This chapter has described the current concept for OA support from FFI to deployed Norwegian forces in Faryab, Afghanistan. Experiences from the first three contingents of OA support indicate that the concept is working well.

Currently the Armed Forces have adopted a 3 + 6 month rotation plan, that is 3 months for preparation and 6 months deployment. The operational analyst follows the same rotational pattern. This allows for a good integration with the rest of the staff. The experience so far with this system is very good, and no change is anticipated or recommended in the coming deployments.

Based on the background of the analyst, it is important to give him/her the necessary basic OA training prior to deployment. It is also important to give a more specific training in relevant computer systems and programs that it is deemed necessary for the analyst to master. This has been somewhat difficult up until now since the tasks have varied a bit and no clear job description exists. With more experience and a clearer job description this should become more streamlined.

¹⁹ Defence Science and Technology Organization.

The need for reach back has been different from contingent to contingent, and the analysts have used it to a varying degree. However, when needed the reach back capacity has always proven to be useful. Given the limited capacity of only one deployed analyst, reach back is a key success factor in the deployment of operational analysts from FFI.

4 OA support to PRT Meymaneh

Operational analysis can be defined as the “application of scientific methods to assist executive decision makers” [12]. This is a very wide definition and gives a lot of opportunities to the deployed analyst with regards to the specific tasks to undertake. This chapter will summarize the main tasks each of the analyst in the PRT XII, PRT XIII and PRT XIV contingents have contributed to.

4.1 OA support to PRT XII

PRT XII deployed in December 2008 and for the first time with OA. Being the first analyst to deploy, very little information was available with regards to the areas of responsibility that the analyst would be given. Given the fact that operational analysts, as described above, have not deployed on a regular basis before, no experience of how to utilize the analyst existed within the military organization. This forced the analyst to be very proactive and on his own identify tasks that would support the commander’s decision process. This section describes some of the tasks the analyst in PRT XII conducted.

Campaign assessment

Assessing the achievements of the operations that have been conducted is one of the core areas where an operational analyst can contribute [12]. In order to be able to support this process, it was necessary for the analyst to develop a framework for measurement of effectiveness (MOE) and the consequent assessment of these MOEs.

PRT XII developed an Effect Guidance Matrix (EGM) as a tool for governing their ongoing and future operations. In this matrix the area of operations was divided into different sub-areas in order to differentiate between various levels of ambition. For each of the sub-areas a set of top-level effects was established which again was broken down into a set of sub-effects assessed to contribute to the overall top-level effects. These sub-effects were then used as guidance for tasking the different sub-units in the PRT.

In order to assess the status and progress on the different sub-effects and top-level effects, the analyst developed a set of MOEs as well as a description on what kind of data that would be needed in order to give a sufficient assessment. This was one of the main tasks that the analyst participated in and it lasted throughout the entire contingent.

Lessons learned

Being able to identify and incorporate lessons learned (LL) from conducted operations is an important aspect of military operations. The nature of this work, involving a lot of data gathering and analysis, makes it an ideal area of interest for the operational analyst.

PRT XII conducted after action reviews (AAR) after the completion of each operation. The operational analyst participated in all these meetings to record the different lessons identified (LI). These LIs were then stored in a database and became subject to analysis in order to identify how to improve operations effectiveness. The analyst was also responsible for filing reports on the subject to higher headquarters.

Polling

An important task for the operational analyst in PRT XII was related to data collection by the use of polling. The PRT wanted to focus on how the soldiers were perceived by the local population in Meymaneh city, since this is a focused area for the PRT. To get this understanding the operational analyst, in close co-operation with the PSYOPS/INFO OPS officer, developed and conducted a survey with approximately 500 respondents in Meymaneh city. The information gathered from this survey was then analyzed by the operational analyst and formed the baseline for future assessment of population perception in Meymaneh city.

Ad hoc analysis

Introducing a new function and deploying as a single analyst into a staff unit that has had the same features for many contingents, made it challenging to establish the role of the operational analyst. Given the somewhat lacking military experience regarding the use of OA, this task was further complicated. As a result, it is very easy to become a regular staff officer in practice. To a varying degree, all of the analysts covered in this report have experienced this. Accepting the role of regular staff officer resulted in the analyst conducting ad hoc analysis and support to the planning process that ideally should have been conducted by a regular staff officer.

One of the major tasks was CIMIC (civil military cooperation) work. Since the PRT does not have a CIMIC function, OA acted as a point of contact for higher headquarters between their CIMIC and the civilian component of the PRT. This gave an opportunity for a better connection with the civilian advisors.

The planning cell of the PRT staff ²⁰ has a low manning and at times of high work load it is necessary for all the members of the cell to pitch in and take their share of the work load. It is therefore understandable that the operational analyst is given some of the more regular staff officer tasks (if she/he has the necessary qualifications to conduct them).

²⁰ The operational analyst is organizationally placed in the S3/5/7 planning cell

4.2 OA support to PRT XIII

The second analyst deployed with PRT XIII and had a hand over take over (HOTO) period of one week with the redeploying analyst. In this period, the focus was on what had been done by the redeploying analyst and what possibilities existed for the new analyst. The analysts in contingent XII and XIII had different backgrounds and different preparations prior to deployment. This naturally led to the new analyst having a somewhat different approach to OA tasks than the previous analyst. The fact that PRT XIII also had minimal experience of having an operational analyst in the staff contributed to the focus shifting somewhat from the previous contingent. This section describes some of the tasks the analyst in PRT XIII conducted.

Campaign assessment

The new contingent continued to use the EGM as an important tool in the operational planning sequence. As the focus of each contingent has a tendency to shift from one contingent to the next, the EGM also changed accordingly. The basic area of application however remained the same, and the need for assessing status and progress was still present.

The assessment of progress according to the EGM became one of the main tasks of the operational analyst in PRT XIII. However, there were some changes in how the actual assessment was done. In order to conduct the assessment, a framework was developed. This framework was based on a survey where S2 and S3 assessed the achieved results for the different sub-effects on a scale from 1 to 4. In addition to the quantitative assessment, the respondents were asked to write an explanation for their individual assessment. The analyst then compared the results from the respondents and summarized them in a report for the PRT as a whole. In this methodology it is not the numbers gathered in themselves that are the interesting information, but the development from one assessment cycle to another and the explanations for the individual assessment given by the different respondents. At several occasions the discussion from the report helped the PRT leadership to develop a better and more unified situational awareness.

The assessment framework described above is a subjective framework where the opinion of the different subject matter experts makes up the assessment. As such it is less suitable for assessing progress on a long term basis, as assessment will undoubtedly change when new people take over the responsibility. However, as a tool for assessing the progress within one contingent, the framework described above will give a valuable contribution.

The assessment framework was complemented with activity analysis (as described in the next point) and development analysis. The latter gave an overview of development work in the province. This included where the projects were located (in which districts), what kind of projects and how many (completed and ongoing). The overview was also compared to the security situation.

In an ideal world the progress indicators or measurements of effectiveness (MOEs) should be objective metrics that are observable over time. Given the limited collection capacity of the PRT it can, however, be challenging to establish this type of framework.

Activity analysis

Another important task the analyst in PRT XIII conducted was the activity analysis. The aim of this analysis was to give the PRT leadership an overview of the situation when it came to security and development (governance was to a lesser degree included due to the lack of a political advisor in the first half of PRT XIII). This was continuously incorporated into the campaign assessment in order to complement the subjective assessments.

A major part of the activity analysis was a comparison of PRT activity and insurgent activity and the subsequent analysis of these data in order to, if possible, identify trends and draw conclusions. The analysis compared the insurgent activity, PRT activity and key events in the society (e.g. harvesting, election and so on) during a four month period of the contingent. Based on the analysis the operational analyst was able to establish a better understanding of how the insurgents operated compared to the PRT and society in general. The analysis received good feedback from the leadership of the PRT and was used in the commander's different presentations.

Lessons learned

The focus on lessons learned (LL) in PRT XIII was not the same as in PRT XII and consequently the focus of the operational analyst was also different regarding LL. The focus on AAR continued with the new PRT, as this is an integral part of the military organization. However, the systematic recording of lessons learned from these AAR became less distinctive in PRT XIII. The analyst continued to follow the different AAR, but not in the same systematic way as before. In connection with large scale focused operations the analyst conducted a more in-depth analysis of the AAR and wrote a lessons learned report.

Ad hoc analysis

The analyst in PRT XIII was also tasked with a lot of ad hoc analysis and what could be called standard staff officer duties. Given the way Norway are trying to implement OA in the military organization this is impossible to avoid. In light of the situation on the ground in the PRT, with limited staff capacity, it is also necessary for the analyst to take on these types of tasks in order to contribute to the overall achievements of the PRT. None of the other specialist officers in the PRT staff escaped this situation either, and in order to show the usefulness of having a deployed analyst it is necessary to, at times, have a pragmatic view towards what kind of tasks the analyst conducts.

As for the previous analyst, CIMIC work was a major part of the OA work. This was useful for the campaign assessment.

4.3 OA support to PRT XIV

The third analyst from FFI deployed with PRT XIV and had a HOTO period of two weeks with the redeploying analyst. During this period the redeploying analyst was able to give the new analyst a good overview of what had been done during the previous contingent and what possibilities the new analyst had. Compared to a HOTO period of one week, a two week period

give the new analyst a much better starting point for his contingent, and for future rotation a HOTO period of two weeks should be advocated.

The new analyst again had a different background and preparation than the previous analyst, and even though the HOTO period was very good, the focus of the new analyst shifted somewhat compared to the previous analyst. The experience of having an analyst in the staff was also low in the PRT XIV staff, and this also contributed to refocusing the work. Some of the tasks from the previous analyst were continued and some were reduced in favour of other types of analysis. This section describes some of the tasks the analyst in PRT XIV conducted.

Activity analysis

One of the tasks that were continued by the new analyst was the activity analysis comparing PRT activity and insurgent activity. The analysis conducted by the analyst in PRT XIII covered a period of four months of the contingent. In PRT XIV, the analysis was expanded to cover a period of two years. By expanding the time frame of the analysis, it was possible to get a better picture of how the situation had developed as well as verify the conclusions from the analysis in PRT XIII using a larger dataset. The analysis was also expanded to include other elements that could be interesting when trying to explain the development in insurgent activity. The analysis received good feedback and was several times used by the commander, in his presentations, to underline his message.

In order to conduct the analysis, a lot of data was needed. The collection of these data revealed a lack of systematic approach to information management. As a consequence, one of the other main tasks of the operational analyst in PRT XIV was the development of a database for information sharing.

Information sharing database

The PRT in Meymaneh has been under Norwegian command since 2005 and during this time a lot of information has been collected and stored in different files on the file server. As the amount of information has grown over the years it has also become increasingly difficult to maintain an overview of what information is stored and who has the responsibility to update it.

The intention by developing the database was to remedy some of these challenges by storing more information in one place and at the same time making it available to more people within the staff. As part of the development process, a standard operating procedure (SOP) was developed that laid down the responsibility for updating the different information elements in the database.

The information contained in the database is illustrated in Figure 4.1.

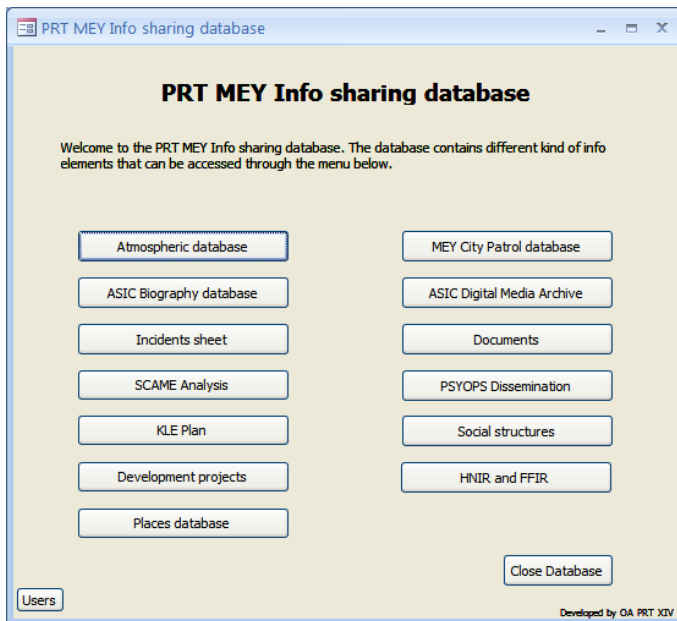

Figure 4.1 PRT MEY Information sharing database – main menu

A more in-depth description of each of the elements in the database can be found in Appendix A.

Ad hoc analysis

The analyst in PRT XIV experienced the same situation as the previous analysts, being tasked with different ad hoc analysis and more general staff officer duties. These tasks were primarily related to aiding the planning process with the production of order briefs through the use of MARIA and other visualization aids.

4.4 Common OA tasks

This chapter has described some of the tasks that the deployed analysts have conducted. It is evident that there will be differences between the different contingents regarding the focus and tasks of the analyst. However, based on the experience of PRT XII–PRT XIV, the following should be defined as core OA tasks.

1. Campaign assessment

The campaign assessment process is a very important process where the analyst can contribute substantially. This is also an area which is often neglected without an operational analyst in the staff, as the responsibility may fall between the operations (S3) and intelligence (S2) branches.

2. Lessons learned

This area has been managed very differently by the different contingents. Never the less, this is an important area for analysis, and the operational analyst should have a central role in this work.

3. Data gathering and structuring

The operational analyst often needs a lot of data for his/her analysis. The collected data can often also be useful for other analyses in other parts of the planning cell/staff. A central task for the analyst is therefore to structure the collected data in a manner that facilitates further use. A natural extension of this is the more formal structuring of information as a whole, an area often referred to as information management.

5 Lessons identified

Based on the experiences from the three first operational analysts that have been deployed from FFI to Afghanistan, the following main lessons have been identified.

Job description

The wide definition of OA, as described in [12], illustrates the broad range of opportunities in exploiting a deployed analyst as an integral part of a military headquarter. This is a positive aspect, but can also become a challenge as the commander does not necessarily have experience with the use of an operational analyst. The development of a short job description indicating what we define as the core OA competency and what we think the analyst should be involved in is therefore a necessary action. This job description has to be known and accepted by the military organization.

In general, each contingent has a slightly different way of operating, including the staff. And with no or little experience with OA it is likely that this capability will be utilised in different ways by the contingents. It is necessary for each operational analyst to adapt to her/his contingent, but a guiding job description may provide the necessary continuity in the OA work as well as better use of the analyst. The three OA tasks identified in Chapter 4.4 may form the core of such a job description.

Necessary preparations

The FFI is a multi-disciplinary research institute and therefore the scientists have a wide educational and knowledge background before they are deployed as operational analysts. Based on the background of each analyst, it is necessary to give her/him a good pre-deployment training before starting the deployment with the unit. This training should include knowledge of the military decision making process as well as OA methodology and models. The use of Norwegian Defence Command and Staff College, OA courses and unit pre-deployment training are useful arenas for preparing the analyst.

The operational analyst is one of the elements in the PRT staff where continuity between contingents easily can be achieved. In order to achieve this, the deploying analyst should be given an introduction to what the previous analysts have done and which tasks it is relevant to continue pursuing for the new analyst. This introduction combined with the job description will give the new analyst a good start on his deployment.

In-theatre hand over take over

The new contingent deploying to the area of operations (AO) often uses three weeks to deploy all forces. When planning this deployment, effort should be taken to assure that the operational analyst deploy so that she/he has a two week hand over take over period. In order to succeed with this, it is of course also necessary for the redeploying analyst to make sure that her/his redeployment date is in accordance with the deployment plan of the new analyst.

Number of analysts and reach back

The number of analysts deployed should ideally be more than one. This will allow for a more comprehensive OA support and is in line with the recommendations in [12]. In a situation with limited resources this can of course be difficult to achieve. Given the limited capacity of only one deployed analyst, reach back is a key success factor in the deployment of operational analysts from FFI.

Raise awareness about OA

One of the main experiences from the three first deployments is that operational analysis is not known among the staff officers in the Norwegian Defence. Initiatives to raise the awareness about what OA is among current and future staff officers may therefore be useful. The focus of such initiatives should be towards the students at the war colleges and the staff college.

Military contract

The current contract system works well. Some changes might be required with civilian ranks being implemented in the near future, but overall this change will not have significant impact on the current OA concept.

Appendix A PRT MEY Info sharing database

This appendix contains a more in-depth description of different information elements in the PRT MEY Info sharing database, developed by the operational analyst in PRT XIV.

Atmospherics information

This part of the database contains the information from the basic information requirements reporting concerning atmospheric data. Atmospheric data is data about the population's attitude towards own forces. After registration in the database it is possible to visualize the data in MARIA, the Norwegian Defence map tool.

ASIC biography information

The biography database contains information on different actors in the PRT Meymaneh area of operations (AO). The information is primarily related to insurgents and the different reports the PRT receives from their sources. The information stored in this part of the database is classified as secret due to its sensitive nature.

Incident sheet

The incident sheet contains data on all the recorded incidents in PRT MEY AO with information about location and detailed record of the incident. The information in the database can be visualized in MARIA and also exported to the map tool in the unit's battlefield management system (BMS), so that all units have access to the most up to date information when they are out on operations.

PSYOPS SCAME analysis

The SCAME analysis tool is a PSYOPS analysis tool used to analyse collected propaganda from insurgents. The SCAME abbreviation stands for Source, Content, Audience, Media and Effect and is used by the Information Operations officer when analyzing collected propaganda.

Key Leader Engagement Plan

The key leader engagement plan contains information on the key messages to be communicated to the different key leaders and the responsibility within the PRT for communication the message.

City Patrol database

The city patrol database contains information on the patrols that has been conducted in Meymaneh city with details on the routes used and the events that took place. This information is necessary in order to not create a foreseeable pattern of operations that again can make the PRT forces easy targets.

Digital media archive

The digital media archive contains information on pictures and video recorded of areas or persons of interest in PRT MEY AO. For the information to be relevant it is important that the necessary metadata is recorded. The metadata relates to grid, direction and location of the information. The information is possible to visualize in MARIA.

PYSOPS dissemination database

The PSYOPS dissemination database contains information on where PSYOPS products have been distributed and the main target of the dissemination. This information can be of vital interest when assessing the effects of a PSYOPS campaign.

Social structure database

The social structure database contains information on the different social structures in the Faryab province. The intention is that information on the following social structures should be stored in the database:

- Courthouses
- District administrations
- Health clinics
- Prisons
- Schools
- ANP structures

Abbreviations

AAR	After Action Review
ANP	Afghan National Police
AO	Area of Operations
ASIC	All Source Intelligence Cell
BMS	Battlefield Management System
CD&E	Concept, Development and Experimentation
CPT	Close Protection Team
CS	Combat Support
CSS	Combat Service Support
DEVAD	Development Advisor
DSTO	Defence Science and Technology Organization
EGM	Effect Guidance Matrix
EOD	Explosive Ordnance Disposal
EW	Electronic Warfare
HOTO	Hand Over Take Over
INF	Infantry
INFOOPS	Information Operations
IO	International Organizations
ISAF	International Security Assistance Force
ISTAR	Intelligence Surveillance Target Acquisition and Reconnaissance
JTAC	Joint Tactical Air Controller
KFOR	Kosovo Force
LI	Lessons Identified
LL	Lessons Learned
MOE	Measure of Effectiveness
MOT	Military Observer Team
NAD	Norwegian Aeromedical Detachment
NBG	Nordic Battle Group
NC3A	NATO Command, Control and Consultancy Agency
NDCSC	Norwegian Defence Command Staff College
NJHQ	Norwegian Joint Headquarters
OA	Operational Analysis
POC	Point of Contact
POLAD	Political Advisor
PRT	Provincial Reconstruction Team
PSYOPS	Psychological Operations
SCAME	Source Content Audience Media Effects
SFOR	Stabilisation Force in Bosnia and Herzegovina
SOP	Standard Operating Procedure
TG	Task Group

References

- [1] F. Rutledal, "Direkte støtte til militære hovedkvarter og operasjoner Sluttrapport etter FFI-prosjekt 1003 Analysestøtte til FOHK", FFI-rapport 2009/01247 (Unntatt offentlighet), 2009.
- [2] PRT Executive Steering Committee, "Charter of the Provincial Reconstruction Team (PRT)", (Unclassified), 2004.
- [3] O. Eronen, "PRT Models in Afghanistan, Approaches to Civil-Military Integration," *CMC Finland Civilian Crisis Management Studies*, vol. 1:5 2008.
- [4] NATO, "PRT Handbook 2nd edition", (Unclassified), 2006.
- [5] C. Coning, H. Lurås, N. N. Schia and Ståle Ulriksen, "Norway's Whole-of-Government Approach and its Engagement with Afghanistan", NUPI Security in Practice 8, 2009.
- [6] E. Marthinussen, "Joint Effort og Joint Future 2007 – fellesoperative øvelser ved FSTS", FFI-notat 2007/02329 (Begrenset), 2007.
- [7] C. Sendstad, "(U) Operasjonsanalyse ved Forsvarets stabsskole", FFI-notat 2008/00892 (Begrenset), 2008.
- [8] M.K. Fidjeland og S. Gulichsen, "(U) Joint Effort og Joint Future 2009 – operasjonsanalyse ved fellesoperative øvelser", FFI-reiserapport 2009/01124 (Begrenset), 2009.
- [9] M. Værholm, "(U) Fellesoperativ modul ved Forsvarets stabsskole – med fokus på assessment under Joint Effort 2010", FFI-reiserapport 2010/01181 (Begrenset), 2010.
- [10] E. Marthinussen, T. H. Jacobsen og R. Anvar, "Kurs i operasjonsanalyse ved ORS i Birmingham 2006", FFI-reiserapport 2006/01681 (Unntatt offentlighet), 2006.
- [11] E. Marthinussen, "Joint Predeployment Operational Analysis Course 14. april–9. mai 2008, Canberra, Australia", FFI-notat 2010/00825 (Ugradert), 2010.
- [12] NATO RTO SAS, "Decision support to Combined Joint Task Force and Component Commanders", AC/323(SAS-044)/46 (Unclassified), 2004.